



TOP VIEW

SPECIFICATIONS	
MANUFACTURER	CLEANAWATER
MODEL:	TS 1500 PE
CONSTRUCTION MATERIAL (SHELL):	POLYETHYLENE
CONSTRUCTION MATERIAL (LID):	POLYETHYLENE
NOMINAL FLOW RATE:	0.42L PER SECOND (1500L/HR)
MAXIMUM LOADING:	0.83L PER SECOND (3000L/HR)
WASTE WATER INLET:	DN40 BSPF
WASTE WATER OUTLET:	DN50 BSPF
WASTE OIL OUTLET:	DN25 BSPF
SLUDGE OUTLETS:	DN40 BSPF
WATER CAPACITY:	380 LITRES
DRY WEIGHT:	30 KG
OPERATING WEIGHT:	380 KG
PUMP	DIAPHRAGM\HELICAL ROTOR



FRONT VIEW

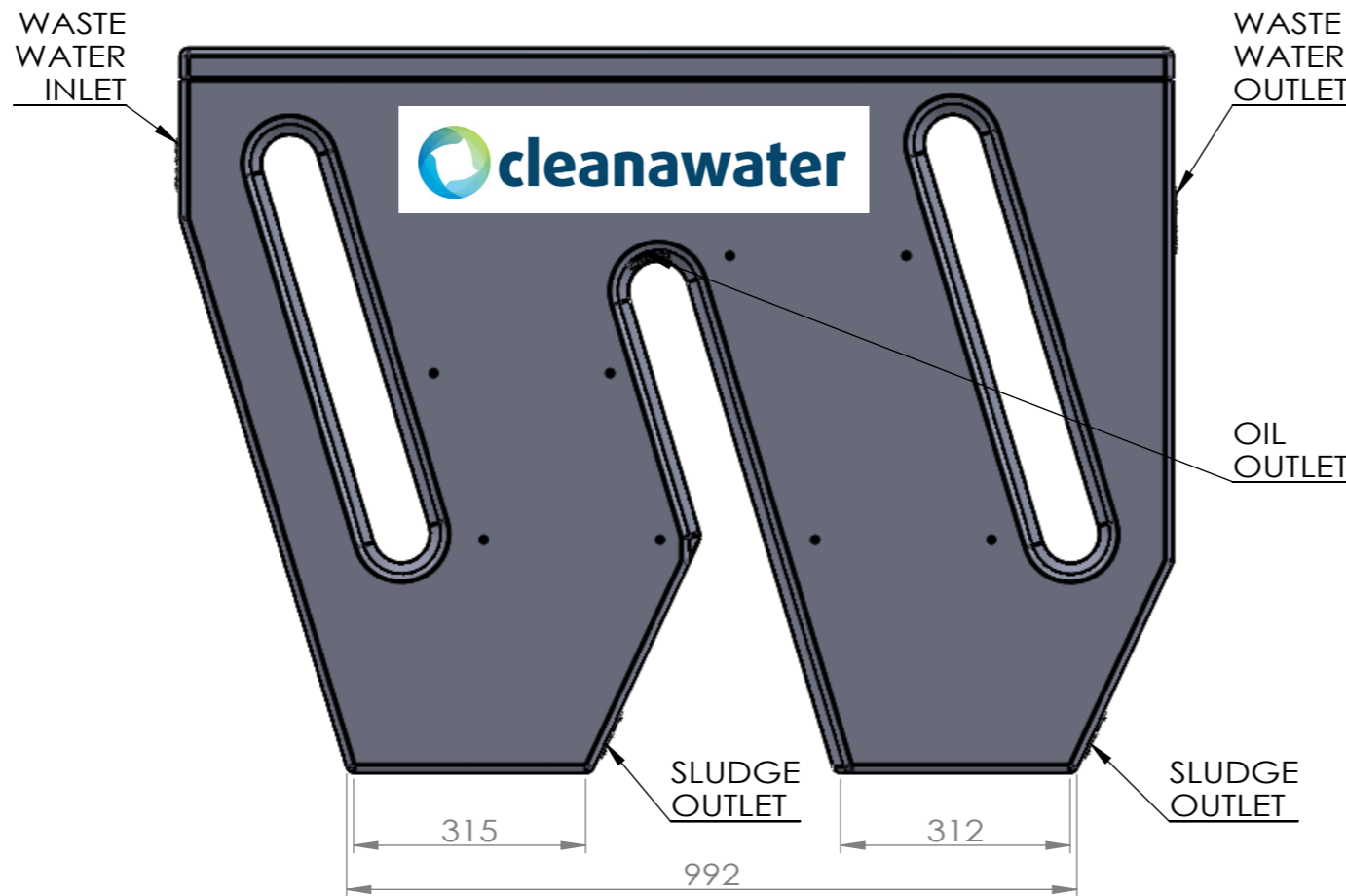

RIGHT ELEVATION

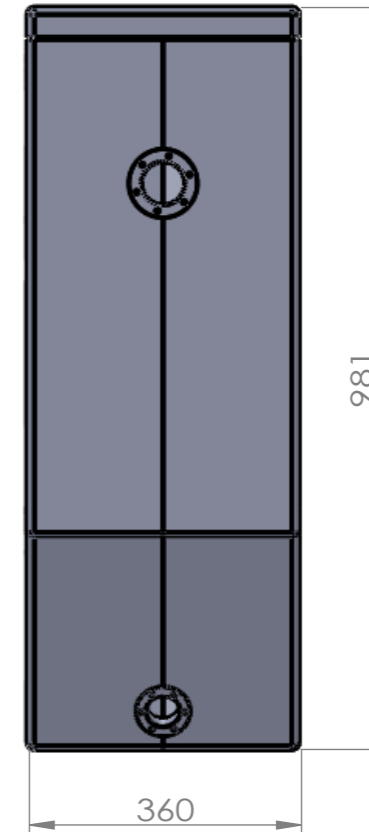

REAR VIEW

TITLE: <b>TS 1500 PE OIL WATER SOLIDS SEPARATOR</b>	DWG NO. <b>AA - 019</b>		UNLESS OTHERWISE SPECIFIED: DIMENSIONS ARE IN MILLIMETERS SURFACE FINISH: TOLERANCES: LINEAR: ANGULAR:	MATERIAL: <b>POLYETHYLENE</b>	NAME	SIGNATURE	DATE	REVISION	PROPRIETARY AND CONFIDENTIAL THE INFORMATION CONTAINED IN THIS DRAWING IS THE SOLE PROPERTY OF CLEANAWATER. ANY REPRODUCTION IN PART OR AS A WHOLE WITHOUT THE WRITTEN PERMISSION OF CLEANAWATER IS PROHIBITED.
	SHEET 1 OF 1	SCALE: n/a		A3	DO NOT SCALE DRAWING	WEIGHT: 30 KG	DRAWN J.S	5/2013	
					CHK'D R.D		5/2013		